



SPARTAN

4.5 kW | Diesel Heater

Power:	1400-4500 W (4,700-15,300 BTU)
Fuel:	Diesel, HVO
Operating Voltage:	12 V
Fuel Consumption:	0,16-0,46 l/t (5.4-15.5 oz/h)
Electricity Consumption:	0.7-4.5 A
Air Volume at Min Heat:	102 m ³ /t (60 cfm)
Air Volume at Max Heat:	227 m ³ /t (133 cfm)
Weight:	15 kg



As one of the most powerful Wallas models, the Wallas Spartan offers the most advanced control features in the marine heater market, maximizing convenience and versatility. The Advanced Control Panel can be accessed remotely by Wallas mobile app, which enables you to turn the heater on from anywhere. The wireless sensor monitors the indoor temperature with high accuracy, maintaining smooth temperature stability for maximum comfort. When narrowing down your options, note that **Spartan Twin** has two makeup air inlets and two warm air outlets. In comparison, the **Spartan Air** has three inlets and outlets for increased airflow and efficiency. Several fresh air hoses produce cleaner and fresher air indoors and improve efficiency. In addition to fossil diesel, the Wallas Greenboost burner burns renewable diesel (HVO) cleanly and energy-efficiently, resulting in very low NO_x and CO₂ values.



3008 ADVANCED

THERMO | Intelligent Control Panel

- Use heater in **Thermo Mode** to hold a target room temperature.
- Switch to **Manual Mode** to deliver heat at six power levels.
- Blow fresh air without heating in **Ventilation Mode**.
- **Air Boost Mode** provides superior ventilation volume for extremely fast defrosting and drying - The highest in its class!

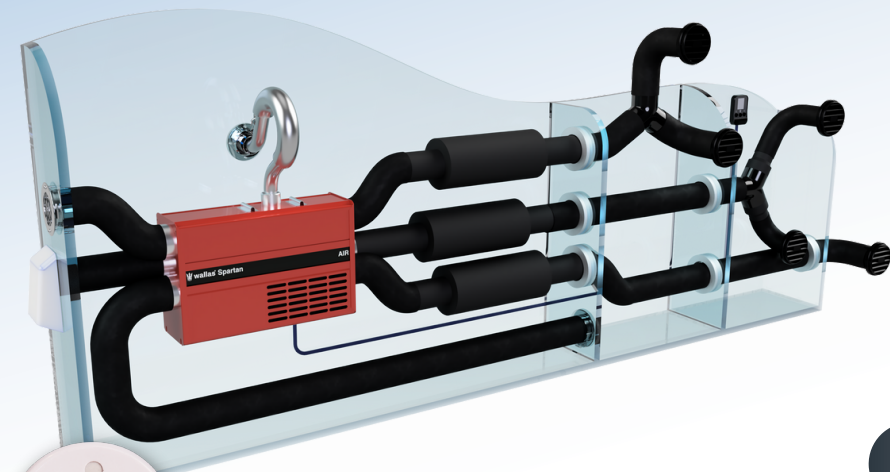

Multiple inlets take fresh air from outside and heated return air from the cabin. This improves efficiency and ensures oxygen rich air in the cabin.

Multiple outlets reduce air drag and keep the sound level low.



Wireless temperature sensor monitors cabin temperature with improved accuracy and flexibility.

INSTALLATION

Easy installation can be done independently or by a Wallas professional.

Spartan Air

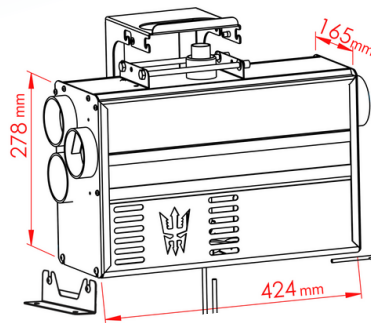

2448/2045

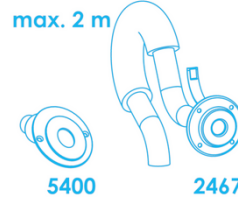

3425



Spartan Twin

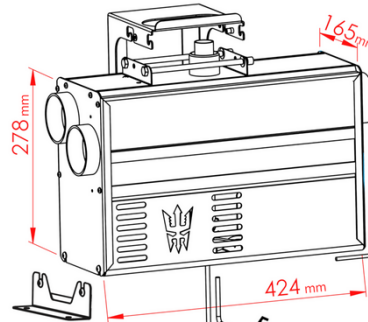

4413

3410

4411

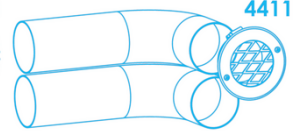

3441/3411



3416

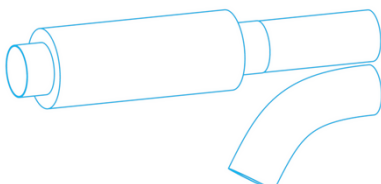

3417



3410/3419



3418



3413



4416



2419



2417



2441/2411



2418



12 V



4432



3008



4 m



5 m



30012



30011



4 m



367200



5 L



10 L



362608



Recommended Builds

Boats: 9-12 m (29-40 ft)

Camper Vans: MB Sprinter

Trailers, Containers: up to 8 m (26 ft)

FEATURES

- Multipoint remote temperature sensing for improved accuracy.
- Multiple inlets and outlets allow greater installation flexibility and drying performance.
- Superior ventilation volume in Air Boost mode.
- Warranty 2+1 years.
- Variable output eliminates system cycling and reduces noise, keeping you comfortable.
- Brushless blower motors have a very long life-cycle, supporting reliably long service intervals.
- Fully enclosed laminar burning process ensures a quiet sound level and wind resistant burn.
- Low temperature on unit and exhaust pipe increases safety.
- Made of stainless steel, high-grade aluminum, and other corrosion-resistant materials.
- Drawing fuel directly from the main tank of the vessel saves space and eliminates the need for a separate tank.
- E-mark approved for vehicles.



Accessories in black come with the standard package. Accessories in blue are additional/optional. Wallas-Marine reserves the right to change or improve its products and to make changes in the content of this brochure without obligation to notify any person or organization of such changes or improvements. Go to www.wallas.fi for current updates and supplemental information concerning these products.